



Multilin EPM 9900P

High Performance Power Quality Meter with Transient Recording and Phasor Measurement Unit (PMU)

The Multilin™ EPM 9900P is one of Multilin's most advanced power quality meters and provides comprehensive perspective of energy usage; capture of power quality events and easy integration with support for multiple protocols to provide key decision making and monitoring information for critical energy circuits in utility substation or industrial applications.

Key Benefits

- Ideal for revenue and power quality monitoring in applications such as of utility substations, advanced industrial manufacturing, datacenters and hospitals with features such as IEC 61000-4-30 Class A Ed. 3 Power Quality Measurement; high resolution transient recording (up to 50Mhz) and high accuracy 0.06% Watt/Hr energy metering with demand and time of use capture.
- Phasor Measurement Unit (PMU) Capability
- Constant Calibration metrology self calibrates every 10 seconds ensuring highly stable readings
- Large 4GB memory to log years of captured data
- Easy integration with flexible communications options and protocol support including Modbus, DNP, IEC 61850, GOOSE Messaging, SNMP; IEEE 1588 PTPv2 and IEEE C37.118.2-2011 (Synchrophasor data)
- Field upgradable for future requirements with modular communications I/O and software option upgrades

Applications

- Power quality event capture for utility or industrial event investigation/reconciliation and predictive maintenance (Utility substation, Data Centers, Manufacturing, Hospitals)
- Revenue energy billing or reconciliation (demand, time of use) and for utility or industrial applications
- High speed data capture for external device control in applications such as generation or renewables
- Specialized utility power quality reporting supporting EN50160, IEC 61000-4-30 Class A Ed. 3 standards as well as IEEE 37.118.1-2014 Synchrophasor data

Monitoring & Metering

- 0.06% Energy Accuracy (ANSI 0.2%)
- IEC 61000-4-30 Power Quality Class A Ed. 3 and EN50160 Reporting Support
- Available 50MHz Transient Recorder (over 800,000 samples/cycle)
- Phasor Measurement Unit (PMU) Capability
- Harmonics up to the 511th order (Voltage, Current), 127th order in real time
- Voltage Sag/Swell, Current Fault and Transient Recording
- Up to 4 GB data logging

Advanced Communications

- Modbus, DNP 3.0, IEC 61850 (including high speed GOOSE messaging), SNMP, IEC 1588 PTPv2 and IEEE 37.118.2-2011
- Standard Ethernet communications port with dual Ethernet capability
- Port control to secure and disable services/ports
- Easy system integration supporting up to 32 Modbus TCP/IP sockets per Ethernet port along with configurable Ethernet port services for security

Easy Setup and Use

- User friendly, color touchscreen display
- Software based setup with web server for data visualization
- Available pre-wired meter in NEMA rated enclosure for easy retrofit/new installations



High Performance Power Quality and Transient Meter for Utility or Industrial Applications

The EPM 9900P provides revenue accuracy for energy monitoring and high performance power quality analysis functions including harmonics, flicker and transient waveform capture. Power quality reporting data is collected in compliance with IEC 61000-4-30 Class A and EN 50160 international standards providing users a deep understanding in a variety of utility or industrial applications.

With up to 4GB of data logging, including 50 MHz transient capture, the EPM 9900P ensures that essential power quality data and events are captured, stored, and time synchronized allowing for comprehensive analysis of events. The EPM 9900P also supports a multitude of communications protocols such as Modbus, DNP3 and 61850 making it easy to integrate and retrieve data into a SCADA or data analysis system.

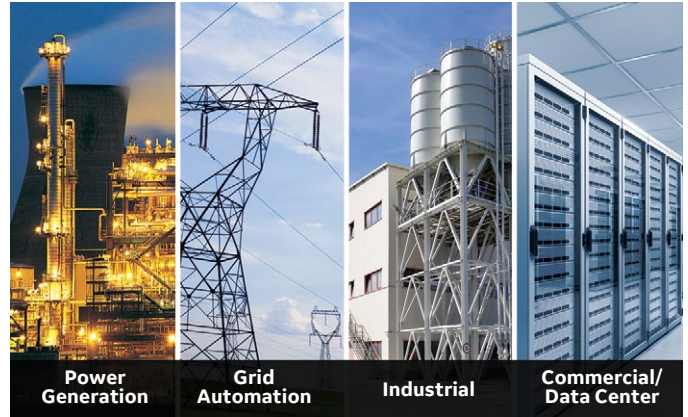

Comprehensive Revenue Energy Metering and Monitoring

With ANSI Class 0.2% accuracy the EPM 9900P provides comprehensive measurements of energy and power quality values as well as monitoring of key electrical conditions to detect and proactively remedy issues to help prevent outages or asset damage.

- Full 4 quadrant metering
- Energy load profiling: log virtually unlimited historical trending
- Time of Use perpetual calendar that supports multiple tariffs
- Transformer and Line Loss compensation: for both iron and copper and total substation losses
- CT and PT compensation: correct for errors in current and voltage transformers
- Coincidental readings: e.g., PF or VARs at time of Peak Demand, to identify number of capacitors needed, peak inefficiencies, etc.
- Load aggregation/universal metering: pulse inputs can be used to aggregate or accumulate different loads such as utility products (Water, Air, Gas, etc.)

Test Mode and Energy Presets

The EPM 9900P meter offers a Test Mode for testing watt-hour and VAR-hour meter accuracy without affecting the stored readings. Using Test Mode, users can verify the meter's readings over the lifespan of an installed meter without having to reset energy or disturb the load profiling and demand recording.

The Energy Preset feature allows a user to program the energy accumulator values upon exiting Test Mode. This lets the user compensate for accumulations missed during testing time, or easily replace the meter during upgrade or maintenance.

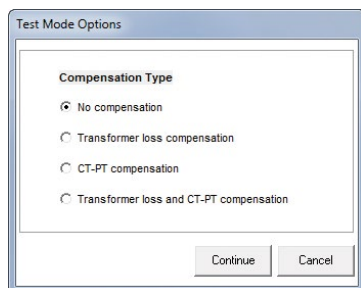

Test Mode to test accuracy without reset

Perpetual Time of Use for Complex Metering

A new feature of the EPM 9900P is the perpetual Time of Use (TOU) calendar that only requires one time setup.

The TOU implementation allows the user to set up multiple tariffs to meet any contractual obligations. It also allows the user to customize any energy parameter for TOU. The 16 available TOU registers can be configured not only for TOU built-in energy readings, but also for any stored data from pulses or RTU Master readings that might need TOU functionality.

System Events Logging

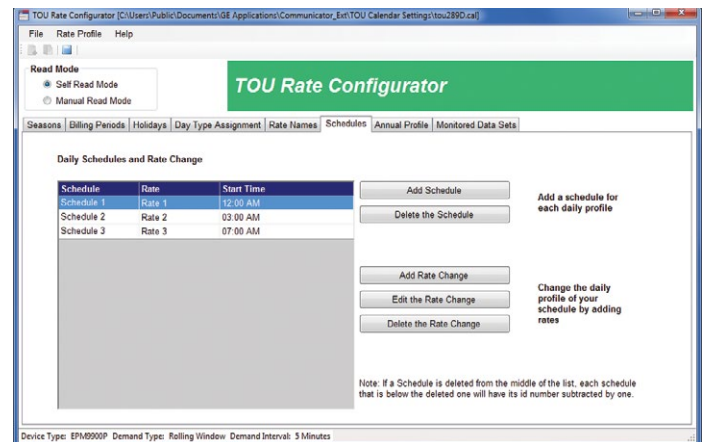

Configure customized TOU tariff schedules

The EPM 9900P logs system operations to detect settings changes and unauthorized access by recording

- Programming changes
- Password access changes
- Time changes
- Resets/Power up/down
- Firmware changes

Class A Power Quality Reporting

The EPM 9900P captures and stores comprehensive power quality information, including harmonics, sags, swells and transients providing a clear perspective and log of faults and disturbances to allow for detailed and extensive forensic engineering analysis.

IEC 61000-4-30 Class A Ed.3 Power Quality Meter

- Designed specifically to meet the rigorous IEC 61000-4-30 Class A Ed. 3 standard, the EPM 9900P measures and analyzes power quality metrics precisely.
- All reporting is available via the EN 50160 reporting format which can be further customized to meet the required application or regulatory needs.

IEC 61000-4-15 Class A Flicker Meter

- Flicker compliant with the IEC 61000-4-15 Class A standard
- Operates on both 220 volt/50 Hz and 120 volt/60 Hz throughout standard test points

IEC 61000-4-7 Class A Harmonics and Interharmonics Analysis

- View harmonic magnitudes to the 511th order for each voltage and current channel
- Harmonic magnitudes and phase angles in real time are resolved to the 127th order
- Obtain %THD, TDD, and K-Factor
- Conduct power quality analysis at the high end of the harmonic magnitude spectrum

Phasor Analysis

The monitor reads a phase angle analysis between the voltage and current channels, allowing you to analyze efficiency and system integrity.

High-speed Voltage Reliability Measurements

The EPM 9900P meter provides industry leading voltage measurement.

- Real time single cycle RMS measurements
- Customizable high-speed readings – can be set from 2 to 20 cycles RMS

Set Limit Control

Programmable setpoints allowing a user to configure the meter to be used as a control device for many applications, such as:

- Capacitor control
- Load shedding
- Automatic transfer schemes
- Transformer monitoring & control
- Redundant protection (not designed for primary over-current protection)
- Many other control functions

Alarm Notification

The EPM 9900P meter lets you set multiple programmable limits for any measured value, as well as those set up in a Boolean logic tree, and limits set up in the IEC 61850 protocol implementation. Users can be notified of alarm conditions via email.

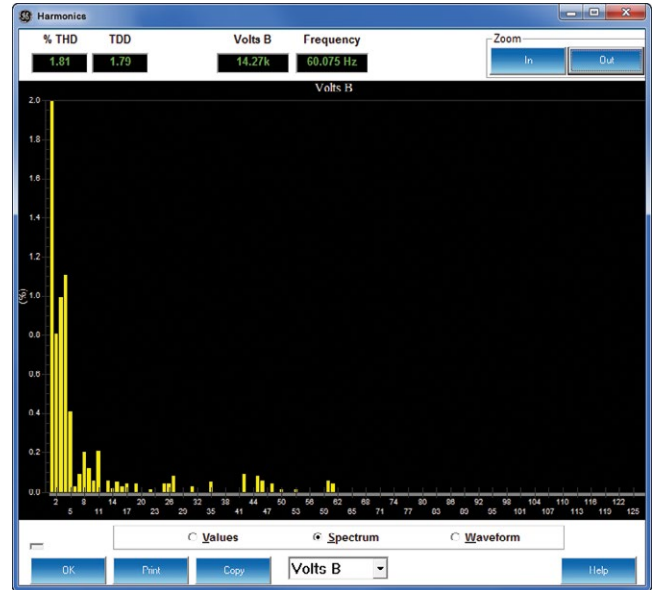

Extensive harmonics analysis capabilities

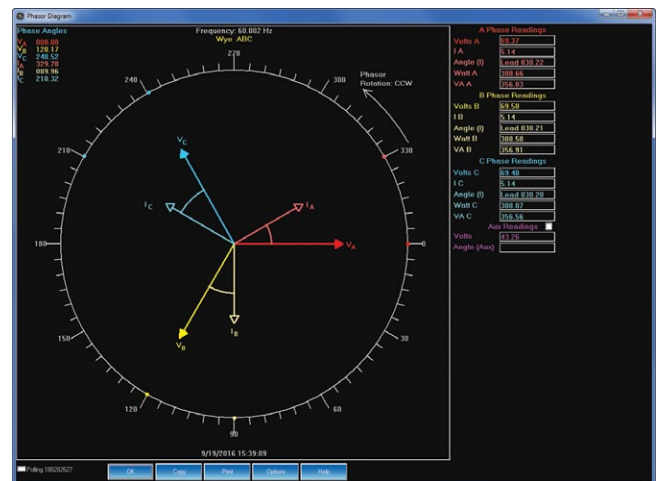

Comprehensive Phasor visualization

EN50160 Individual Report Summary		
	Power Frequency (x.1)	Pass
	Supply Voltage Variations (x.3.x)	Pass
	Rapid Voltage Changes (x.4.1)	Pass
	Flicker PLT (x.4.2)	Pass
	Flicker PST	Pass
	Supply Voltage Dips (x.5)	Pass
	Voltage Swells	Pass
	Short Interruption of Supply Voltage (x.6)	Pass
	Long Interruption of Supply Voltage (x.7)	Pass
	Temporary powerfrequency overvoltage (x.8)	Pass
	Supply Voltage Unbalance (x.10)	Pass
	Harmonic Voltage (x.11)	Pass
	Mains Signaling Voltage (x.13)	Pass

User-friendly reports illustrating PQ compliance

16 Bit Waveform and Fault Recorder

- Record up to 1024 samples per cycle; capture a transient at over 800,000 samples per cycle or at 50 MHz sampling speed
- Voltage and current recording with pre and post-event analysis
- Fault recording offers 8 times full scale capture capability
- 16 bit A/D converter provides precise waveform resolution
- Both hardware and software triggers are available

High-speed Status Input Triggers

- Waveforms are recorded at time of status change
- Input change and waveform recording are time-stamped to a 100 micro second resolution
- Inputs and waveforms can be displayed together to time breakers and relays

Subcycle 50 MHz Transient Recorder (Software Option C)

A user can define log sizes within the meter. Thus the full memory can be allocated specifically to the desired function.

Independent ITIC/CBEMA Log Plotting

- Quickly view total surges, sags, and average duration in the independent ITIC/CBEMA log
- SEMI F47 graphing for power quality compliance in semiconductor industry

Compatible Waveform Formats

Using GE Communicator software, the meter will provide all waveform data via COMTRADE and PQDIF compatible formats. This allows the waveform PQ and fault records to be read by most third-party waveform analysis software programs.

- COMTRADE (common format for transient data exchange) is defined by IEEE Std C37.111
- PQDIF (power quality data interchange format) is defined by IEEE Std 1159.3-2003

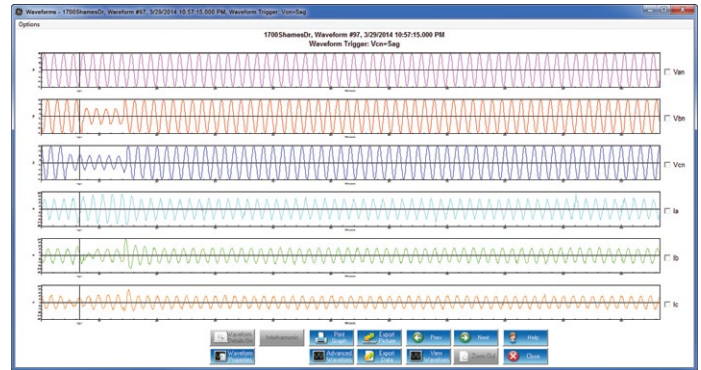
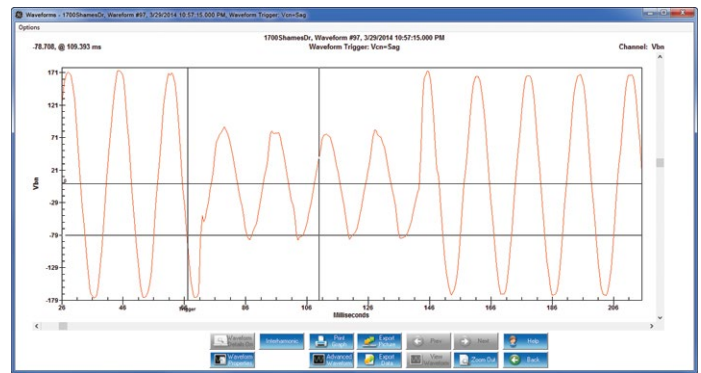

Record and Analyze Waveform Fault and Transient Data

Software Options

The EPM 9900P provides software options to meet specific power quality measurement functionality as well as logging, sampling and communications requirements.

The software options are also upgradeable after purchase/installation. This provides flexibility to expand functionality for future requirements or budgetary approval.

FEATURE	A	B	C	D	E	F
Basic Measurements	•	•	•	•	•	•
Memory	512 MB	1GB	4GB	512 MB	1GB	4GB
Sampling Speed (samples/cycle)	512	1024	1024	512	1024	1024
50 MHz Transients			•			•
IEC 61000-4-30 Class A Edition 3	•	•	•	•	•	•
IEC 61850 Server		•	•		•	•
IEC 61850 GOOSE		•	•		•	•
CyberSecurity				•	•	•
Synchrophasor PMU				•	•	•

Record Phasor Measurement Unit (PMU) Data for Analysis

The EPM 9900P meter has been enhanced with Phasor Measurement Unit (PMU) functionality meeting the IEEE C37.118.1a-2014 standard. A PMU device measures time-synchronized, phasor (magnitude and phase angle of voltage and current) and related data from a specific location on the electrical grid. The data from multiple PMUs are transmitted to a phasor data concentrator (PDC), which aggregates and time-aligns the data for real time and post analysis.

Collection of Synchrophasor data is useful in applications such as:

- Aggregation of instantaneous, time synchronized voltage, current, and frequency at specific locations on the grid for easy greater wide-area system operator situational awareness
- Determination of stress points of the utility transmission system
- Detect and aid in restoration an islanded section of the grid after a storm or major outage disturbance
- Collection and integration of PMU data for visualization in an Energy Management System (EMS).

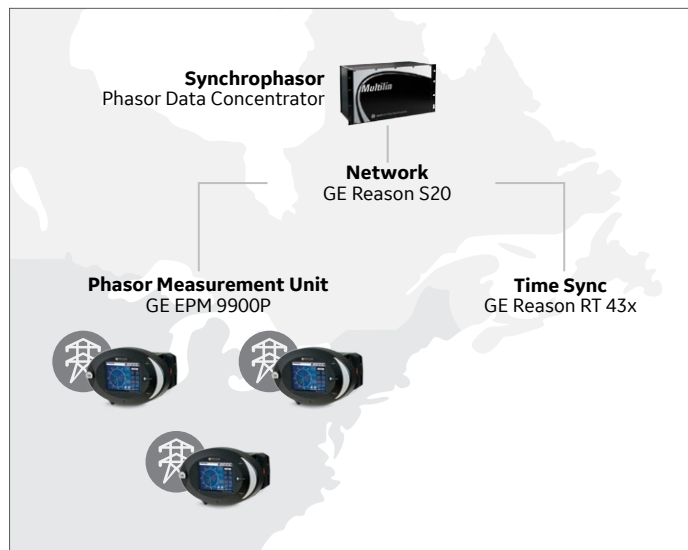

EPM 9900P PMU/Synchrophasor Functionality

EPM 9900P Synchrophasor Features

- Supports both P and M classes
- Time sync standard: IRIG-B or IEEE 1588 PTPv2
- Calculates individual voltage/current phasors, symmetrical components' phasors, frequency, rate of change of frequency, the meter's high-speed digital inputs, analog fundamental power, and displacement power factor
- Data frame rates:
 - 50 Hz - 10/25/50 frames per second
 - 60 Hz - 10/12/15/20/30/60 frames per second
- Data format: configurable float or integer, polar or rectangular
- Support for up to two simultaneous clients with Ethernet or Fiber over Ethernet communication

Enhanced Security Features

The EPM 9900P has been enhanced with additional security features to protect the meter configuration, access and data.

- Secure meter configuration using a digital firmware signature with 512-bit encryption and customizable keys to ensure firmware integrity
- 128-bit AES encrypted communication of sensitive data, such as passwords, usernames, roles, and rights
- Customizable role-based authorization with eight configurable roles
- 24 character complex passwords with password expiration
- Password fail timeouts to address brute force attacks
- Physical seals, requiring physical access to prevent unauthorized tampering
- Security lockout to prevent security from being disabled

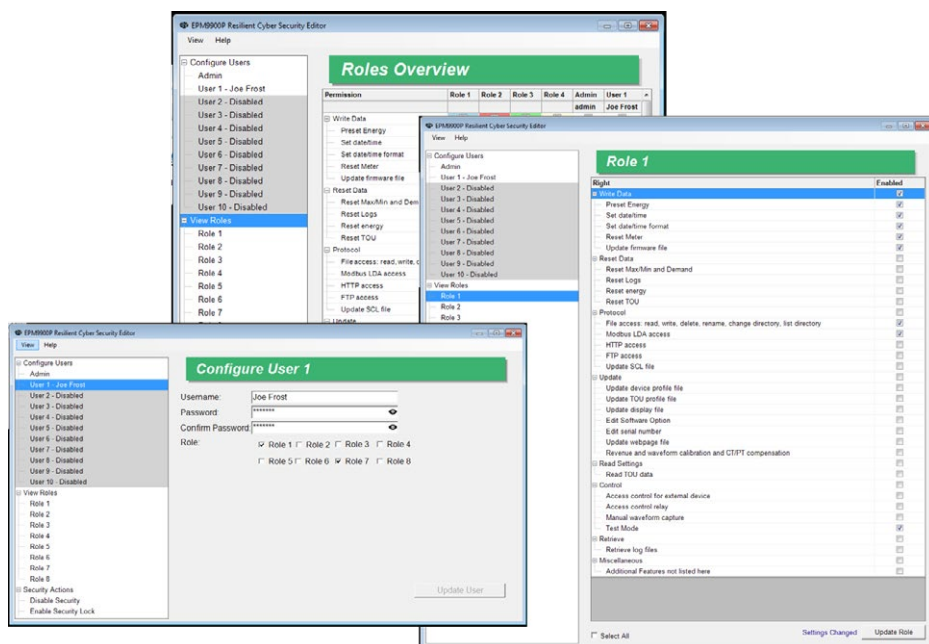

Easy to Configure Security Settings for Users and Roles

Easy System Integration and Available IEC 61850 Solution

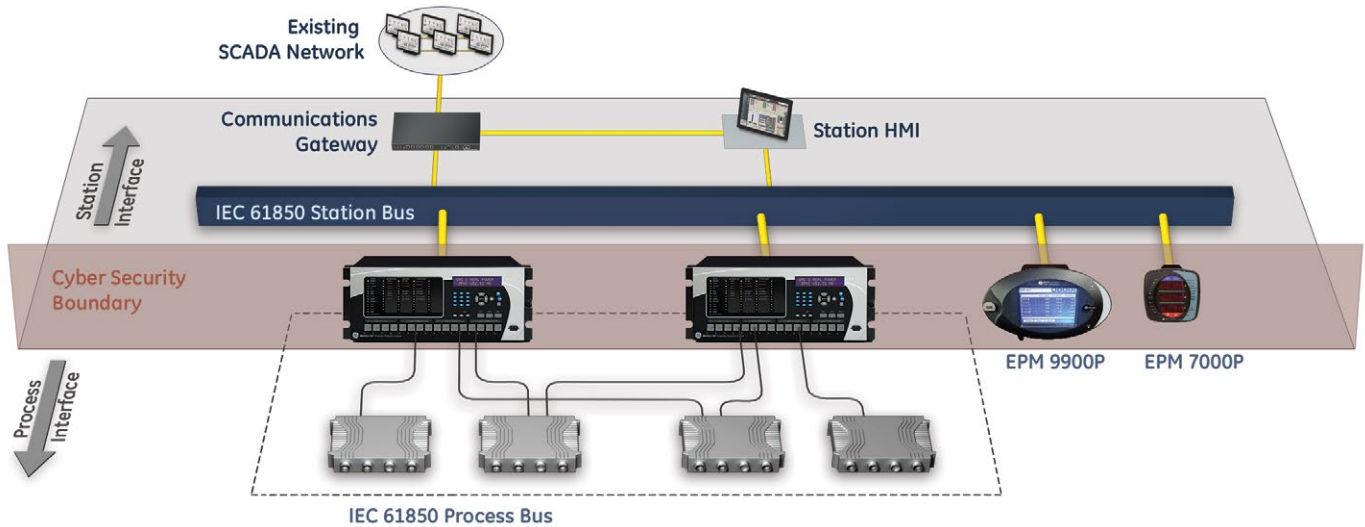

Software options B and above offer an embedded IEC 61850 Protocol Server for seamless integration with substation automation and industrial 61850 applications.

- The IEC 61850 Protocol Server allows up to 6 simultaneous MMS clients.
- Either Ethernet port can be configured for IEC 61850 (only one port at a time can run IEC 61850)
- GOOSE publisher/subscriber functionality is supported.
- Buffered and unbuffered reports are supported for the following triggers: general

meter interrogation, for example, the report is generated in response to a query; meter integrity, for example, the report is generated according to a programmed interval; and data change, for example, the report is generated due to a change in the contents of a dataset.

- File transfer is supported
- Embedded Web Protocol Server support is available for IEC 61850 CID file uploading, IEC 61850 Protocol Server status and for displaying incoming and outgoing GOOSE messages.

- Multiple Logical Nodes, which map flicker, harmonics, digital inputs/outputs, limit state, voltage, current, energy and other data, are supported.
- Waveform capture can be triggered by status input data inside GOOSE messages. The user can program up to 16 status inputs that will trigger a waveform capture when the information is received via a GOOSE message. The status inputs include digital inputs, limit states, and any other status input supported by the meter.

Unique GOOSE Cross Trigger

- Fault-based cross trigger of waveform based on GOOSE message
- Provides system-wide distribution fault analysis on an event
- Timing better than 200 microseconds is typical
- Many different circuits can be viewed after an event occurred

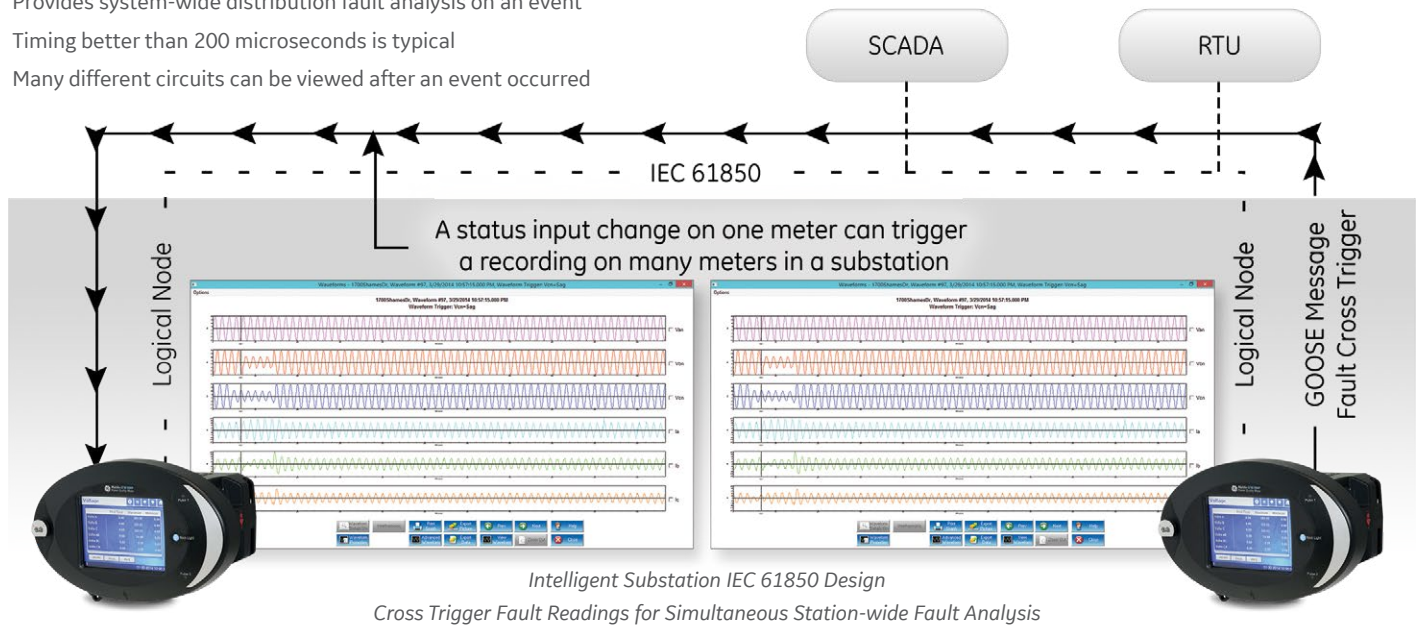

Intelligent Substation IEC 61850 Design
Cross Trigger Fault Readings for Simultaneous Station-wide Fault Analysis

Flexible Communications Options

The EPM 9900P meter offers up to 6 simultaneous communication ports and multiple protocols to meet almost every need.

Hardware Features

- 2 optional RS485 ports speaking Modbus and/or DNP 3.0
- USB front panel port
- ANSI optical front panel port
- 2 separately addressable Ethernet ports
- Optional Fiber or RJ45 media on one Ethernet port

Ethernet Communication Port Capabilities

- 2 Ethernet ports provide multiple simultaneous communication
- Each port has separate MAC address and IP address
- Supports Modbus TCP/IP, DNP 3.0 and IEC 61850
- GOOSE messaging protocol supported for IEC 61850
- Up to 32 Modbus TCP/IP sockets per Ethernet port
- Highly secure port control to disable unneeded services and ports
- Email Function - SMTP email to client on alarm
- Precise Time Synchronization - SNTP Time Sync protocol
- File Transfer Protocol - High-speed file data transfer
- Support for IEEE 1588 PTPv2 for critical time sync applications, e.g., synchrophasor systems.
- IEEE C37.118.2 PMU communication

Industry-Leading DNP 3.0 Level 2 Plus – Complies with DNP Level 1 and Level 2 Certification Requirements

- Up to 136 measurements (64 Binary Inputs, 8 Binary Counters, 64 Analog Inputs) can be mapped to DNP static points
- Up to 16 relays and 8 resets can be controlled through DNP
- Report-by-exception processing (DNP Events) deadbands with unsolicited response for serial communication
- 250 available events, in four event types (Binary Input Change, Frozen Counter, Counter Change, and Analog Change)

SNMP Protocol

SNMP protocol V1 and V2 are supported for managed device networks (i.e. Data center network applications) Features include:

- Support for 40+ measurements
- Traps for limits, input change, and power quality.
- Cold start trap and authentication failure supported.

8 Built-in Digital High-speed Status Inputs

- Inputs automatically sense whether the circuit is externally wetted
- If externally wetted, input up to 150 VDC is accepted
- If internally wetted, the meter supplies the necessary voltage for the control application

VAUX Input

- Neutral to ground or aux voltage readings
- Synchronizing schemes, for example, obtaining the frequency, magnitude, and phase angle on both sides of a switch or between generator and bus voltage

- Standard 10/100 BaseT Ethernet RJ45 Port (Auto-detecting Tx and Rx)
- IRIG-B Satellite Clock: 1 msec Time Sync
- Color-coded Voltage Inputs
- 8 High-Speed Status Inputs

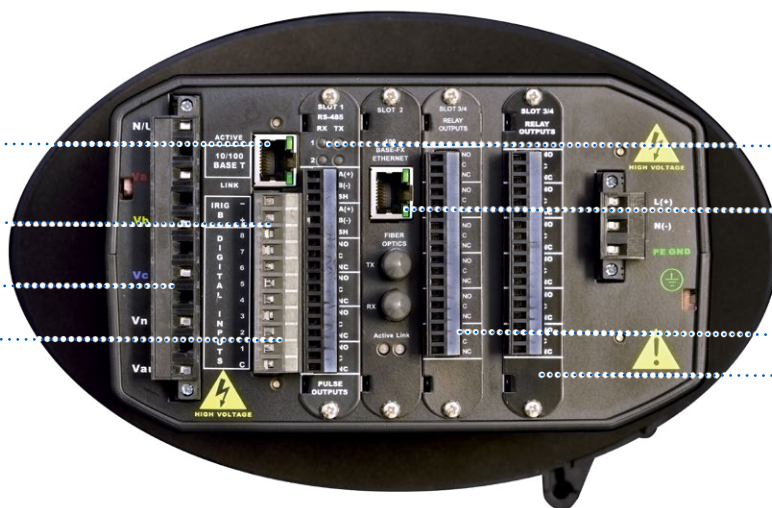

Optional Upgrade Cards

- 2-ports: RS485 and 4 Pulse Outputs
- Optional Second Ethernet Port
- Slots 3 and 4 Provide up to 12 Relay Outputs

Expandible Inputs and Outputs

INTERNAL I/O

Pulse Outputs:

S: Dual Serial RS485/Pulse Output Card

- 4 KYZ pulses - Solid State
- Pulse width: 5 ms
- Two RS485 ports

Relay Outputs:

R1: 6 Relay Output Card

- 5 A, 250 VAC/30 VDC
- Form C (Latching)

Digital Input Status:

DI: 16 Status Inputs Card

- Used for alarm detect or pulse accumulation
- Up to 150 VDC wetted or non-wetted (24 VDC internally provided)

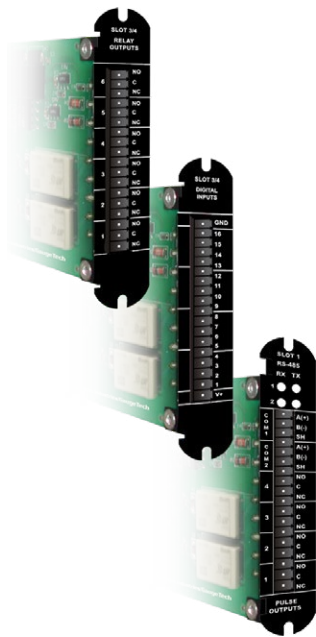

Note: The EPM 9900P provides one I/O slot for the S (Slot 1), and two I/O slots for the R1 and DI (Slots 3 and 4).

EXTERNAL I/O

Analog Outputs:

- PL90001MAON4000/PL90001MAON8000: 4 or 8 Analog Outputs, 0-1 mA, self-powered, scalable, bidirectional
- PL90002OMAON400/PL90002OMAON800: 4 or 8 Analog Outputs, 4-20 mA, self-powered, scalable
- Wiring: Common Mode
- Accuracy: 0.1% of Full Scale
- Calibration: Self-calibrating
- Scaling: Programmable
- Ordering: Up to 4 Analog Output modules

Analog Inputs:

- PL90008AI100000: 8 Analog Inputs, 0±1 mA
- PL90008AI200000: 8 Analog Inputs, 4-20 mA
- PL90008AI300000: 8 Analog Inputs, 0±5 VDC
- PL90008AI400000: 8 Analog Inputs, 0±20 VDC
- Wiring: Common Mode
- Accuracy: 0.25% of Full Scale
- Scaling: Programmable
- Ordering: Up to 4 Analog Input modules

Digital Dry Contact Relay Outputs:

- PL90004RO100000: 4 Relay Outputs, 5 A, 250 VAC/30 VDC, Form-C Latching
- Ordering: 1 module in addition to internal modules

Digital Solid State Pulse Outputs:

- PL90004PO100000: 4 Solid State Pulse Outputs, Form A or C KYZ pulses
- Maximum Pulse Speed: 20 pulses per second
- Ordering: Up to 4 Digital Solid State Output modules

I/O Module Accessories (Required):

- PL9000PSIO00000: Power supply required when using an external I/O module. EPM 9900P does not have internal power for external I/O modules.
- PL9000MBIO00000: Mounting bracket for external I/O modules. Must be ordered with external I/O module.



Color Touch Screen Display

The EPM 9900P meter features a touchscreen LCD color display with a long life LED backlight for increased usability, clarity and visibility in various operating conditions.

Screen displays include:

- Real-time viewing (voltage, current, power, demand)
- Accumulated energy and time of use readings
- Flicker readings
- Alarms
- Phasor Analysis
- Harmonic spectrum analysis and waveforms
- Real time trending
- Log status
- Configuration settings
- Multi-language Support (English, Chinese, Hebrew, Portuguese, Spanish, French, Polish)

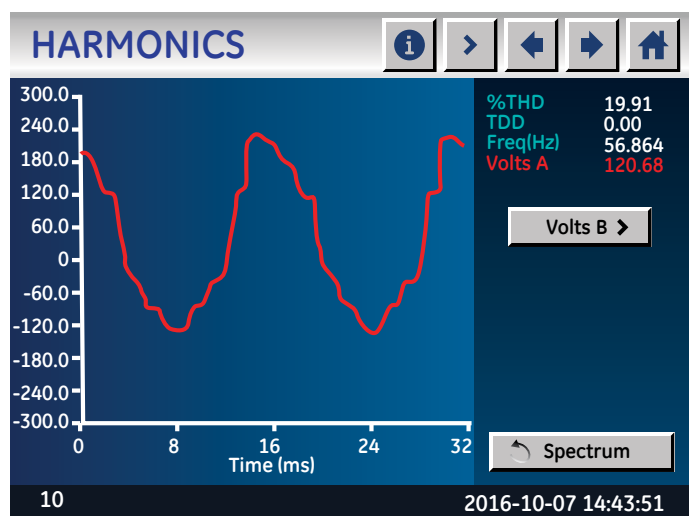
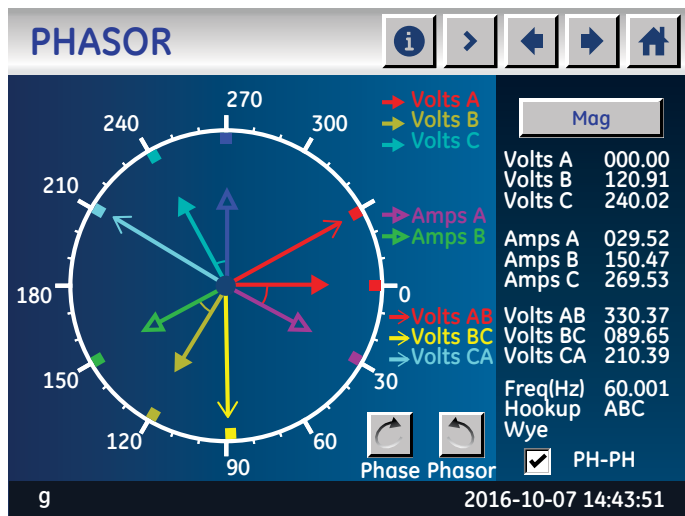

User Friendly Color Touch Screen Display

Multilin Meter Enclosure

Expanding existing switchgear or installing new metering capability can be challenging due to space limitations, downtime and installation and equipment costs. GE's Multilin Meter Enclosure is a pre-wired configured, economical solution for both retrofit expansions and small scale meter installations that allows the expansion of existing switchgear capability without expensive and time-consuming design.

When ordered as a meter option the enclosure provides a factory pre-wired, installation-ready metering solution that further drives energy cost savings, by enabling the measurement of key energy usage information along multiple metering points for new or existing systems. Ordering the enclosure is simple when selected as an option during meter configuration, ensuring correct pre-wired meter-compatible delivery.



Meter Enclosure Assembly

The installation of the GE's Multilin Meter Enclosure is simple, safe and eliminates downtime through simple mounting and wiring. The enclosure is UL/CUL certified and NEMA 1 rated making it ideal for indoor environments.

It is provided in two voltage configurations (120-240V and 277V) to ensure compatibility with customer installations. The standard equipment includes voltage fuses; a shorting block for current transformers; and a control power transformer for 277V power systems that are pre-wired and configured to ensure safety, quality and long-term reliability.

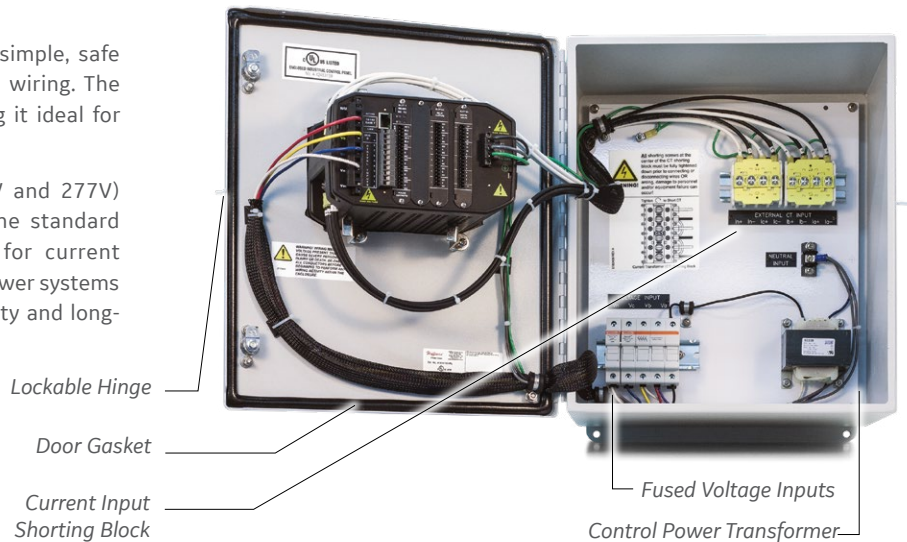

Pre-Wired, Configured and Economical Solution for Retrofit and Small Metering Systems

Easy and Rapid Installation

- Factory pre-wired, installation-ready GE metering solution eliminates wiring and associated errors for rapid installation
- Extend metering capability with new systems and existing switchgear without system installation downtime

Cost-Effective Retrofit Solution

- Save up to 200% versus the addition of a new switchgear cabinet
- Compact footprint makes effective use of existing allocated space
- Allows new installations or the expansion of existing switchgear capability without expensive, time-consuming designs, eliminating system downtime

Reliable and Compatible

- Backed by a 10 year warranty
- Simple meter option ordering ensures compatibility with GE EPM 9900P meters
- Comprehensive factory testing of both meter and enclosure together
- NEMA1 tested and UL/CUL certified

Applications (New and Retrofit installations)

- Utility/Industrial Power Quality Studies
- Healthcare Institutions
- Government Buildings
- Manufacturing
- Educational Campuses
- Data Centers

Wiring Drawings - EPM 9900P Meter

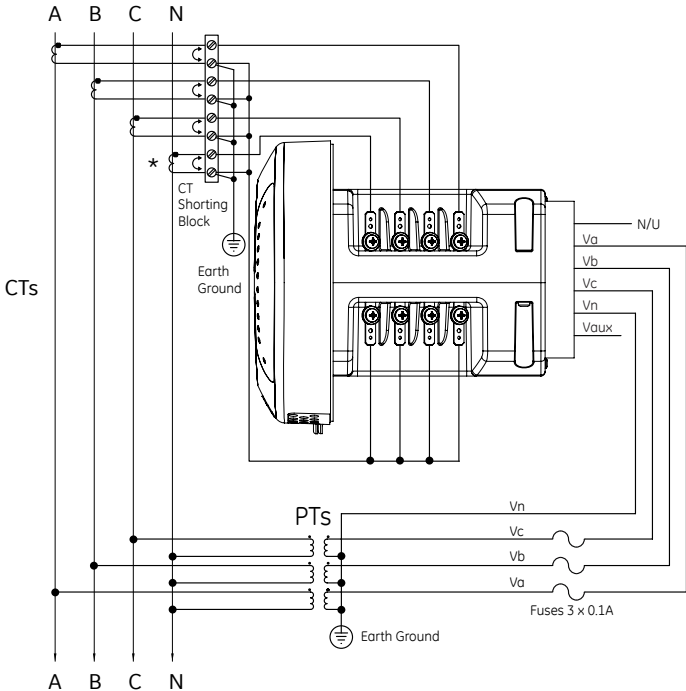

4-Wire Wye, 3 Element with 4 CTs and 3 PTs
*Note: Optional CT for Current Measurement Only

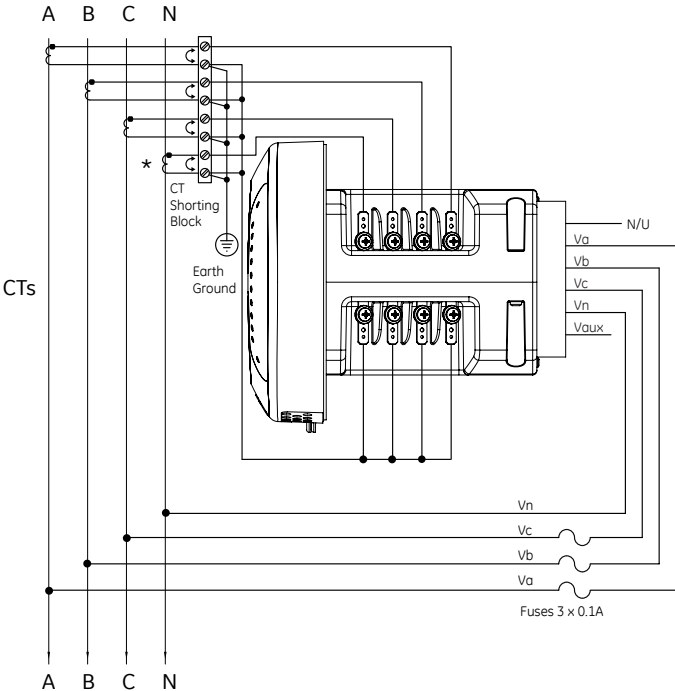

4-Wire Wye, 3 Element with 4 CTs and no PTs
*Note: Optional CT for Current Measurement Only

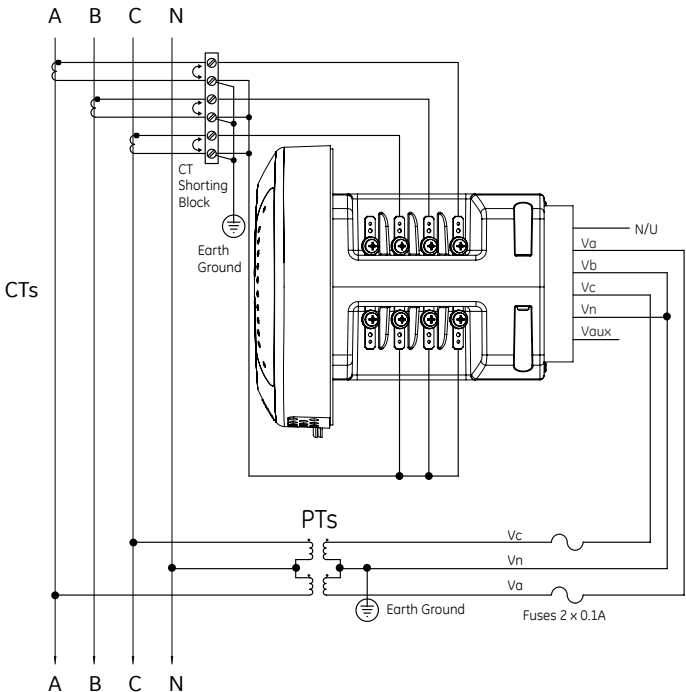

4-Wire Wye, 2.5 Element, 3 CTs and 2 PTs

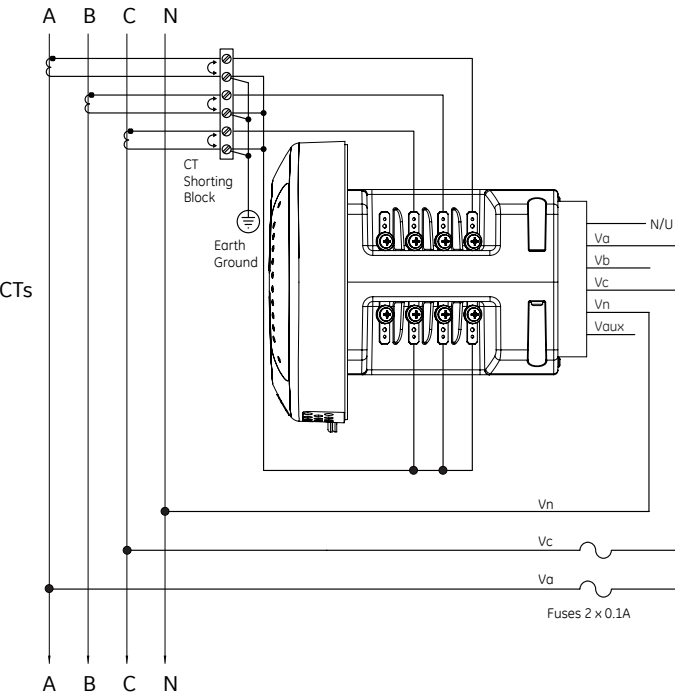

3-Wire, 2 Element Delta Direct with 2 CTs

Dimensional Drawings - EPM 9900P Meter

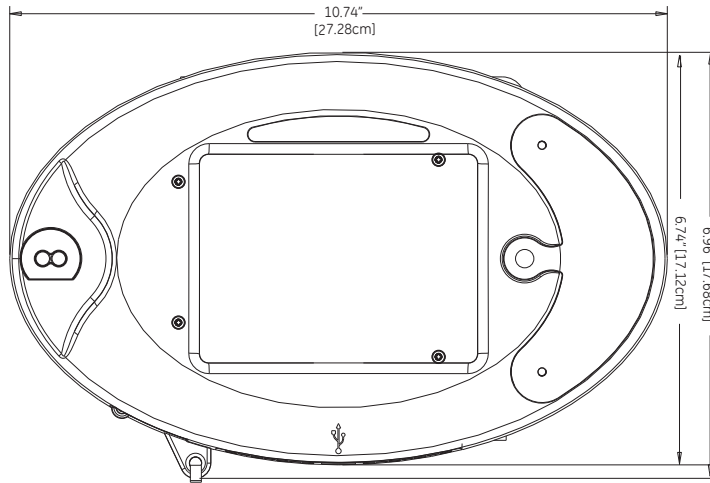

Front

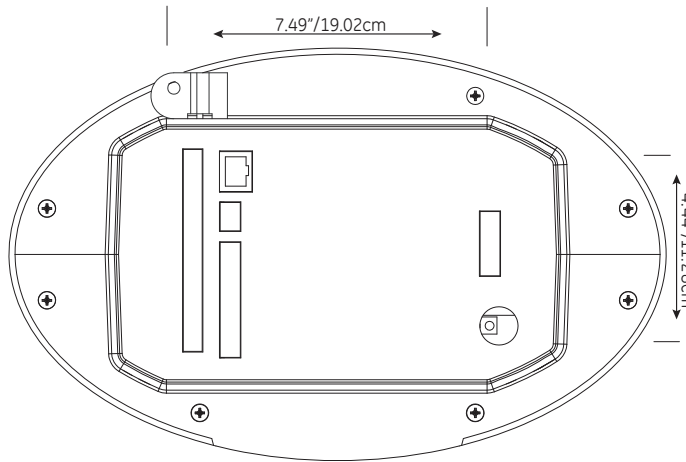

Back

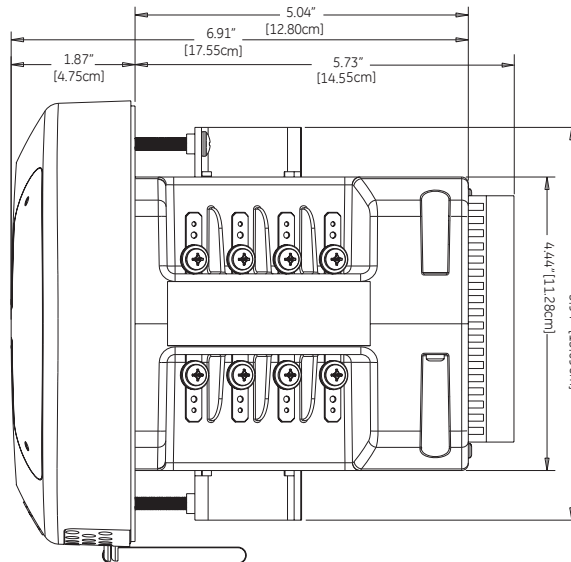

Side

Dimensional Drawings - EPM 9900P Enclosure

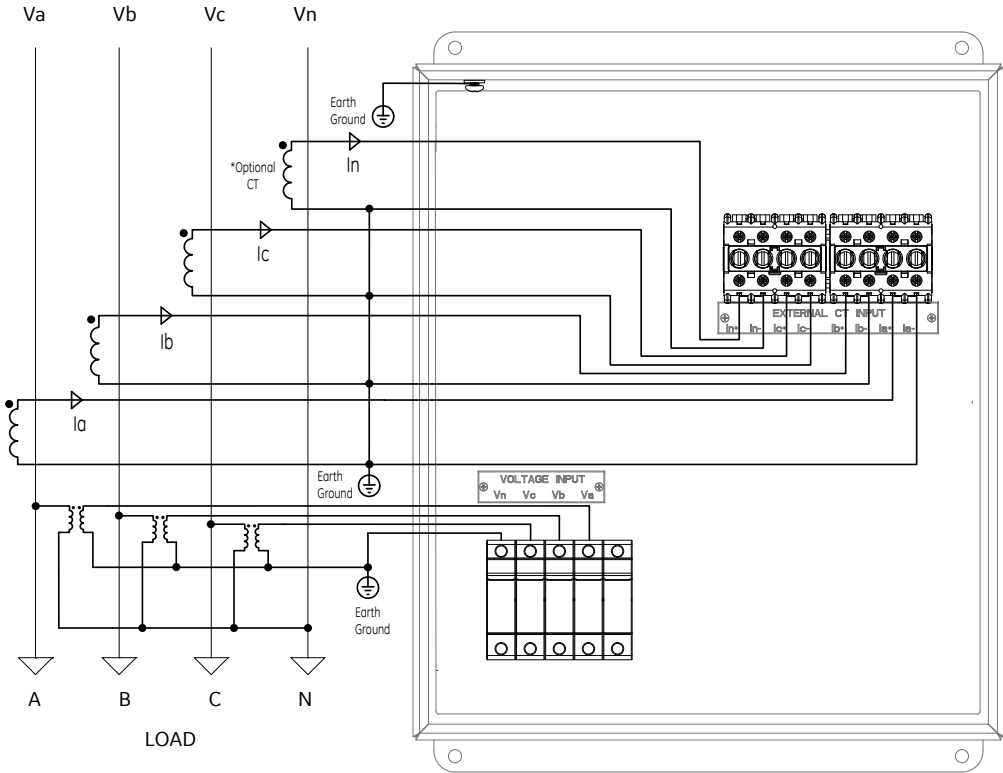
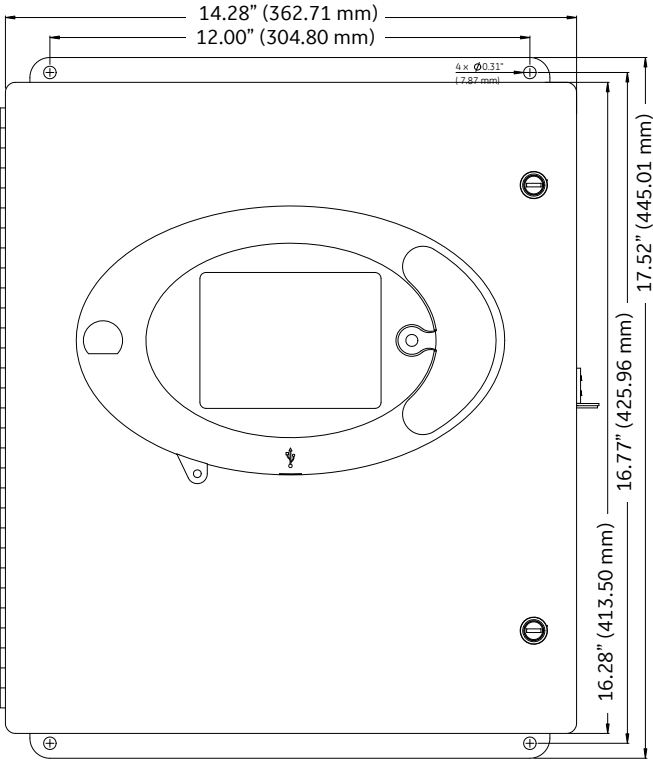
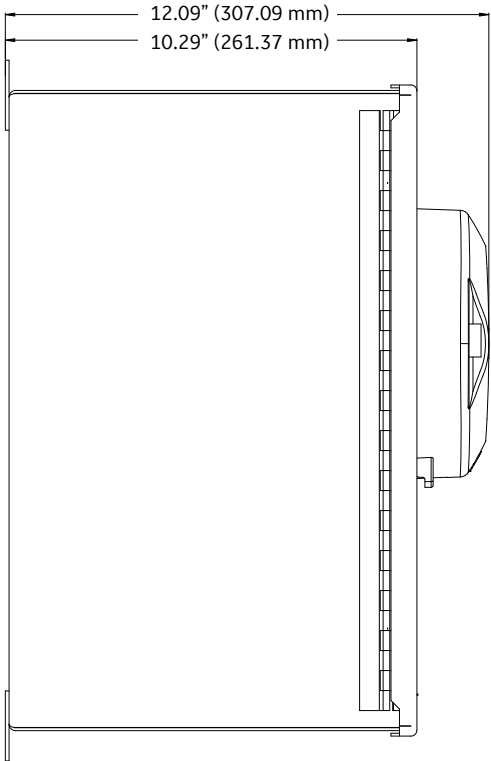

4 Wire WYE 3 PT Hookup, 3 Element

Technical Specifications

INPUT VOLTAGE RANGE

- (5-347)VAC, Line to Neutral
- (10-600)VAC, Line to Line

VOLTAGE INPUT WITHSTAND CAPABILITY

- Voltage Inputs isolated to 2500VAC

INPUT CURRENT RANGE

- Programmable to any CT ratio
- Class 2: Nominal 1 A, with 2 times over range
- Class 20: Nominal 5 A, with 4 times over range
- Class 20: fault current recording to +/- 80 A peak

CURRENT INPUT WITHSTAND CAPABILITY (AT 23°C)

- 100 Amps for 10 Seconds
- 300 Amps for 3 Seconds
- 500 Amps for 1 Second

BURDEN

- Voltage Inputs: 0.072 VA/Phase Max at 600 Volts, 0.003W/Phase Max at 120 Volts
- Current Inputs: 0.008 VA per Phase Max at 20 Amps

ISOLATION

- All inputs to outputs are isolated to 2500 VAC

TEMPERATURE RATING

- Operating Temperature: (-20 to +70)°C
- Humidity: Up to 95% RH Non-condensing
- Storage Temperature: (-30 to +80)°C

SENSING METHOD

- Up to 1024 Samples per Cycle (Programmable)
- 16 Bit A/D Resolution – Multiple Converters
- True RMS
- Constant Calibration™ technology
- Transients measured at 800,000 samples per cycle

ACCURACY RATING

- ANSI C12.20 (Class 0.2) and IEC 62053-22 (Class 0.2S) Accuracy, 0.06% Energy measurement accuracy
- Full accuracy specifications available in User Manual
- Time clock: 3.5 ppm for -40 to +85°C - less than 10 seconds drift per month on crystal sync; 2.0 ppm Typical from 0 - +40°C - less than 6 seconds per month drift

UPDATE TIME

- 1 Second — Revenue Accurate Readings
- 1 Cycle — Faster updated readings
- Customizable high-speed readings from 2 to 20 cycles RMS

CONTROL POWER REQUIREMENTS

- HI Option: (100-240)VAC @50/60 Hz or (100-240) VDC
- AC Option: (100-240)VAC @50/60 Hz
- LD Option: (18-60)VDC (24-48 VDC Systems)
- Burden: 25 VA Max

FREQUENCY RANGE

- 45Hz–69.9Hz

COMMUNICATION FORMAT

- Programmable parity and stop bits
- Communication Protocols: Modbus TCP/IP, ASCII/RTU, DNP 3.0, IEC 61850 (Software Option B or C)
- ANSI Optical Port
- USB 1.1/2.0 Virtual COM Port
- RJ45 Ethernet Port 10/100BaseT
- Standard RJ45 Ethernet Port 10/100BaseT
- Optional Serial RS485 Ports (Meter, I/O card)
- Optional 2nd Ethernet port - RJ45 Ethernet or Fiber Optic

SHIPPING

- Total shipping weight: approx. 6.5 lbs (2.9 kgs)
- Shipping container dimensions: 16" x 15.5" x 11.5" (40.64 cm x 39.37 cm x 29.21 cm)

COMPLIANCE

- ANSI C12.20 (Class 0.2) and IEC 62053-22 (0.2S Class) Accuracy
- ANSI C12.1 (Code for Electricity Metering)
- ANSI C62.14 (Burst)
- FCC Part 15, Subpart B, Class A
- IEC 62053-23 Ed. 1
- IEC 61000-4-2 - ESD
- IEC 61000-4-3 - Radiant Immunity
- IEC 61000-4-4 - Fast Transient
- IEC 61000-4-5 - Surge Immunity
- IEC 61000-4-6 - Conducted Immunity
- IEC 61000-4-7 - Harmonics
- IEC 61000-4-15 - Flicker Meter
- IEC 61000-4-30 - Class A Ed. 3
- IEC 61000-6-2 2005 (Immunity for Industrial Environments)
- IEC 61000-6-4 2006 (Emissions Standards for Industrial Environments)
- IEC 61850 Level A, Ed. 2 Certified
- CISPR11 Ed. 5.1 (Conducted Emissions)
- CISPR22 Class A
- IEC 62052-11 2003- General Requirements
- CE Marked
- UL and cUL Listed

Note: Please see product User Manual for comprehensive specifications.

Ordering

Base Meter	*****	**	*	**	*	*	**	**	**	Description
PL9900P										
Enclosure	ENC120 ENC277 XXXXXX									NEMA1 Rated - Indoor, Single Meter Enclosure, 120V NEMA1 Rated - Indoor, Single Meter Enclosure, 277V None
Control Power		AC HI LD								100-240VAC Power Supply 90-265VAC or 100-240VDC 18-60VDC (24-48VDC Systems)
Frequency			6 5							60 Hz 50 Hz
Current Inputs				5A 1A						5A 1A
Software					A B C D E F					512MB memory with 512 samples/cycle 1GB memory with 1024 samples/cycle, IEC 61850 Communications Protocol 4GB memory with 1024 samples/cycle, IEC 61850 Communications Protocol and 50MHz Transient Recording 512MB memory with 512 samples/cycle, Synchrophasor PMU 1GB memory with 1024 samples/cycle, IEC 61850 Communications Protocol, Synchrophasor PMU 4GB memory with 1024 samples/cycle, IEC 61850 Communications Protocol, 50MHz Transient Recording, Synchrophasor PMU
Slot 1						S X				2-ports RS485 and 4 Pulse Outputs Empty Slot
Slot 2							E1 E2 XX			Second Ethernet Port - 10/100BaseTX, RJ45 Second Ethernet Port - 100FX, Multimode ST Connector Empty Slot
Slot 3								R1 D1 XX		6 Relay Outputs 16 Status Inputs Empty Slot
Slot 4									R1 D1 XX	6 Relay Outputs 16 Status Inputs Empty Slot

Accessories

Internal Input/Output (I/O) Modules

EPM 9900P	Description
EPM 9900P Slot 1	PL9900P-ACC-SXX 2-ports RS485 and 4 Pulse Outputs
EPM 9900P Slot 2	PL9900P-ACC-E1X Second Ethernet Port, 10/100BaseTX, RJ45 PL9900P-ACC-E2X Second Ethernet Port, 100FX, Multimode, ST connector
EPM 9900P Slot 3	PL9900P-ACC-R1X 6 Relay Outputs PL9900P-ACC-D1X 16 Status Inputs
EPM 9900P Slot 4	PL9900P-ACC-R1X (same as Slot 3) 6 Relay Outputs PL9900P-ACC-D1X (same as Slot 3) 16 Status Inputs
Software upgrade	PL9900P-ACC-SAB Upgrade Software option A to B: 1GB memory with 1024 samples/cycle, IEC 61850 Communications Protocol PL9900P-ACC-SAC Upgrade Software option A to C: 4GB memory with 1024 samples/cycle, IEC 61850 Communications Protocol and 50MHz Transient Recording PL9900P-ACC-SBC Upgrade Software option B to C: 4GB memory with 1024 samples/cycle, IEC 61850 Communications Protocol and 50MHz Transient Recording PL9900P-ACC-SAD Upgrade Software option A to D: 512MB memory with 512 samples/cycle, Synchrophasor PMU PL9900P-ACC-SBE Upgrade Software option B to E: 1GB memory with 1024 samples/cycle, IEC 61850 Communications Protocol, Synchrophasor PMU PL9900P-ACC-SCF Upgrade Software option C to F: 4GB memory with 1024 samples/cycle, IEC 61850 Communications Protocol, 50MHz Transient Recording, Synchrophasor PMU PL9900P-ACC-SDE Upgrade Software option D to E: 1GB memory with 1024 samples/cycle, IEC 61850 Communications Protocol, Synchrophasor PMU PL9900P-ACC-SDF Upgrade Software option D to F: 4GB memory with 1024 samples/cycle, IEC 61850 Communications Protocol, 50MHz Transient Recording, Synchrophasor PMU PL9900P-ACC-SEF Upgrade Software option E to F: 4GB memory with 1024 samples/cycle, IEC 61850 Communications Protocol, 50MHz Transient Recording, Synchrophasor PMU
GE Communicator	PLSOFT-COMS GE Communicator for Windows® Single User

External Input/Output (I/O) Modules

Analog Output Modules		
PL9000-1MAON4000		4 Channel 0-1 mA Analog Outputs
PL9000-1MAON8000		8 Channel 0-1 mA Analog Outputs
PL9000-20MAON400		4 Channel 4-20 mA Analog Outputs
PL9000-20MAON800		8 Channel 4-20 mA Analog Outputs
Analog Input Modules		
PL9000-8AI100000		8 Channel 0-1mA Analog Inputs
PL9000-8AI200000		8 Channel 4-20mA Analog Inputs
PL9000-8AI300000		8 Channel 0-5V DC Analog Inputs
PL9000-8AI400000		8 Channel 0-10 V DC Analog Inputs
Digital Dry Contact Relay/Solid State Pulse Outputs		
PL9000-4RO100000		4 Relay Outputs, 5A, 250VAC/30 VDC, Form C Latching
PL9000-4PO100000		4 Solid State Pulse Outputs, Form A or C KYZ Pulses, 20 Pulses/sec. Max.
PL9000 8 Channel Auxiliary Digital Status Inputs		
PL9000-8DI100000		8 Channel Auxiliary Digital Status Inputs
Auxiliary I/O Power Supply		
PL9000-PSIO00000		Auxiliary Power Supply (Required for External I/O Modules)
Auxiliary I/O Mounting Bracket		
PL9000-MBIO00000		Auxiliary Mounting Bracket (Required for External I/O Modules)

GE

650 Markland St.
Markham, ON
Canada L6C 0M1
Toll Free (NA Only): 1-800-547-8629
Tel: 905-927-7070
Fax: 905-927-5098

GEGridSolutions.com

IEC is a registered trademark of Commission Electrotechnique Internationale. IEEE is a registered trademark of the Institute of Electrical Electronics Engineers, Inc. Modbus is a registered trademark of Schneider Automation. NERC is a registered trademark of North American Electric Reliability Council. NIST is a registered trademark of the National Institute of Standards and Technology.

GE, the GE monogram, Multilin, FlexLogic, EnerVista and CyberSentry are trademarks of General Electric Company.

GE reserves the right to make changes to specifications of products described at any time without notice and without obligation to notify any person of such changes.

Copyright 2021, General Electric Company. All Rights Reserved.

GEA-31996A(E)
English
220104

